

**KEYNOTE**  
**A Marriage of Innovation and  
Business Process Management**

**Howard Smith**  
CSC CTO EMEA, Author  
Co-Founder BPML.org  
Founder SouthbeachInc.com

**Applying the methods  
of Innovation to  
Re-Invent Process**

# So you want to improve a business process!

## How shall we model it?

I NEED A \$1,600  
HANDHELD BAR CODE  
SCANNER TO FINISH  
MY LAB TESTS.



www.dilbert.com scottadams@aol.com

OKAY. APPLY FOR A  
CAPITAL BUDGET  
VARIANCE. PREPARE  
AN RFP, GET THREE  
BIDS, FORM A TEAM  
TO EVALUATE THE BIDS,  
THEN PREPARE A  
PURCHASE ORDER.



© 2007 Scott Adams, Inc./Dist. by UFS, Inc.

NEVER MIND. I'LL  
JUST LEARN HOW TO  
READ BAR CODES BY  
SIGHT.



QUITTER.

© Scott Adams, Inc./Dist. by UFS, Inc.

# Executing a process is one thing – improving it is another

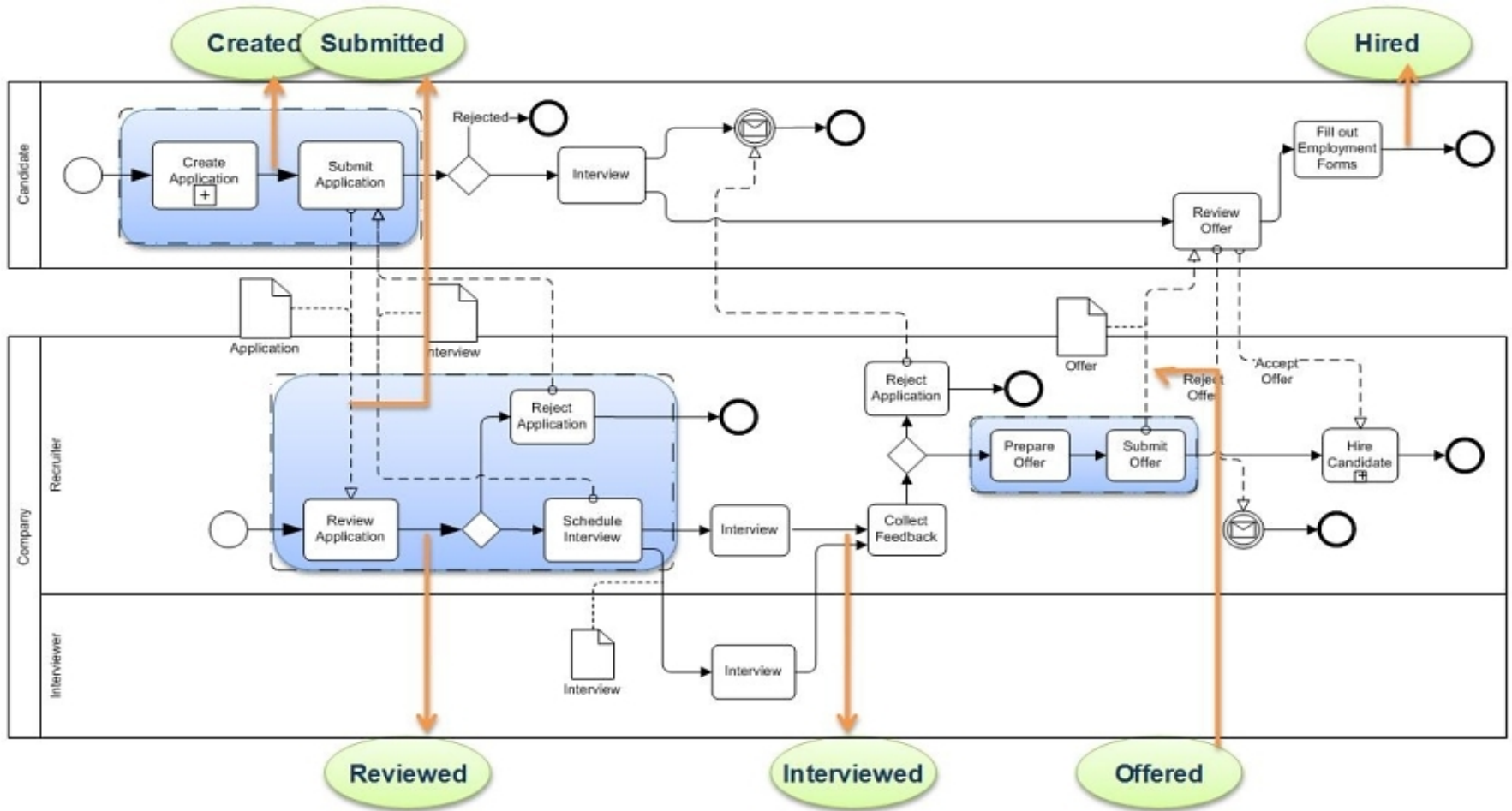

# Executing a process is one thing – improving it is another

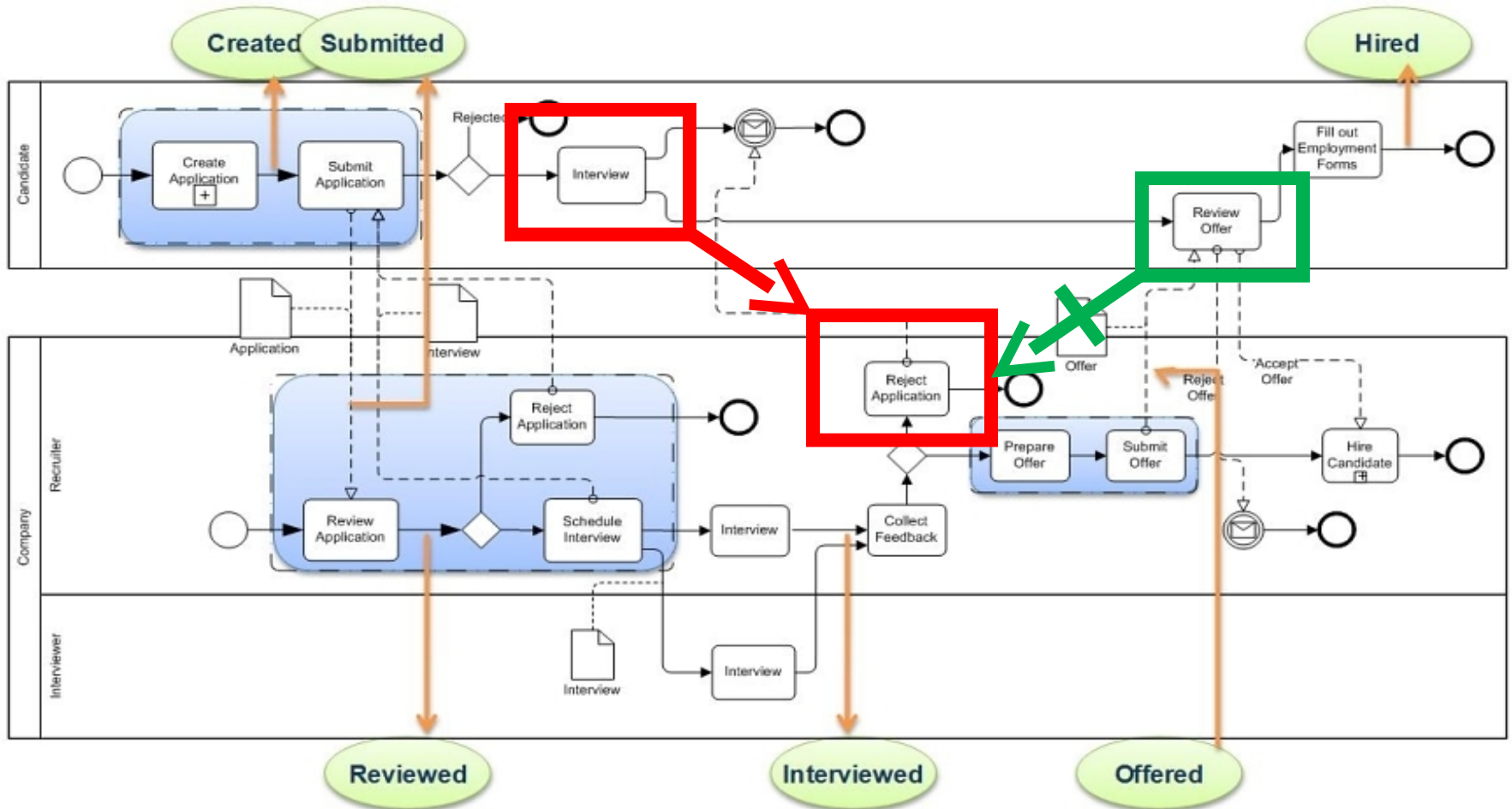

# Introducing a new visual notation - Southbeach



- Southbeach  
Miami, FL.
- June 2005

# Southbeach “idioms”

<http://southbeach-idioms.blogspot.com/>

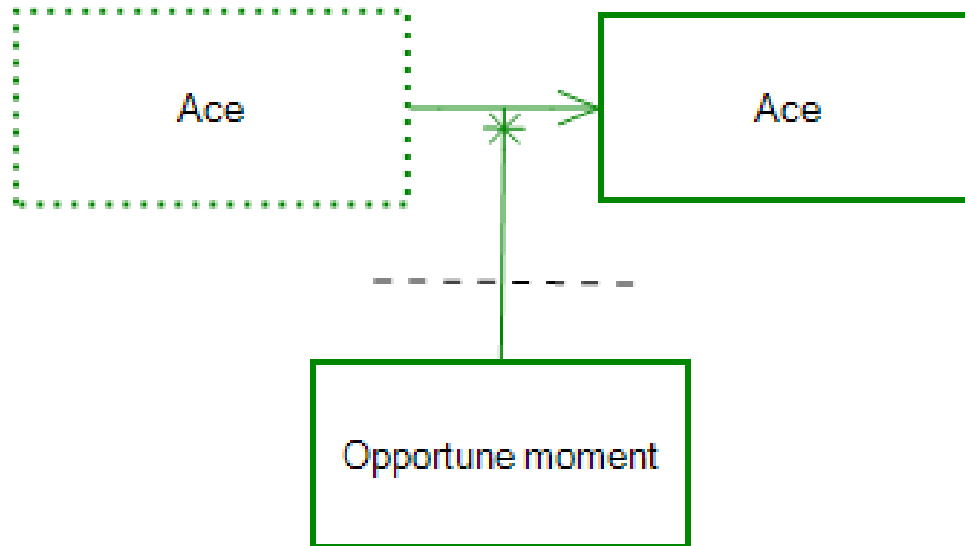

*An ace up one's sleeve*

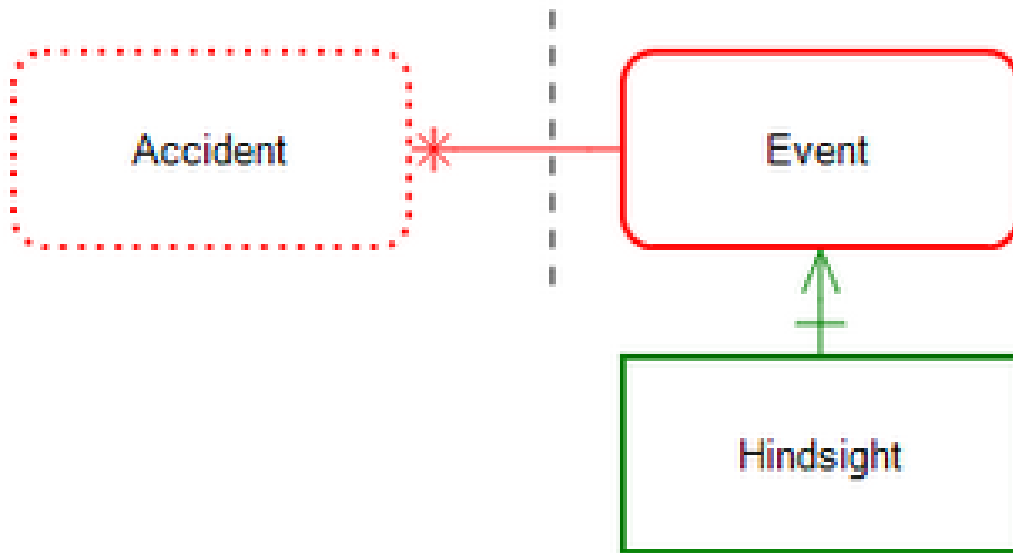

*An accident waiting to happen*

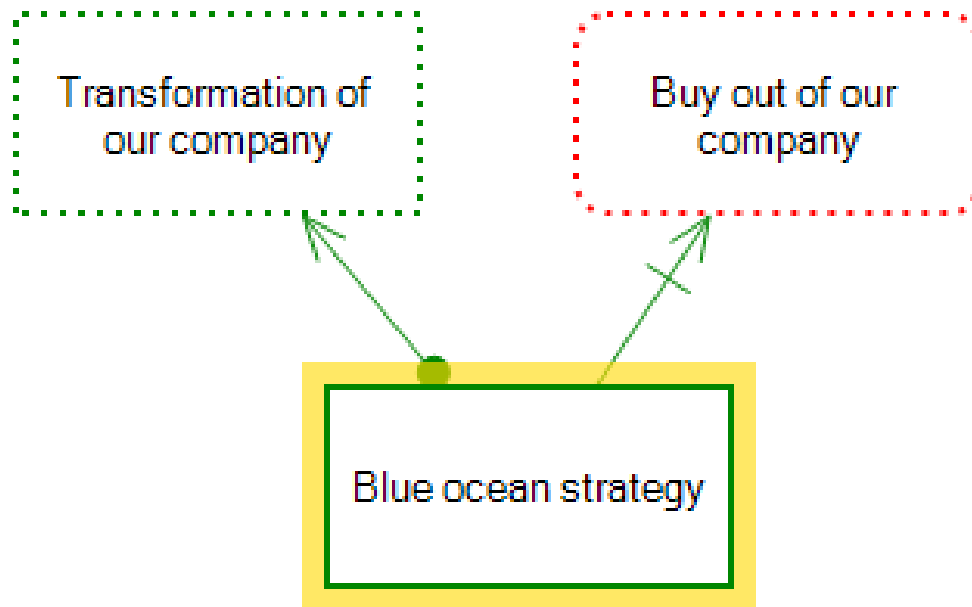

*A new strategy is needed*

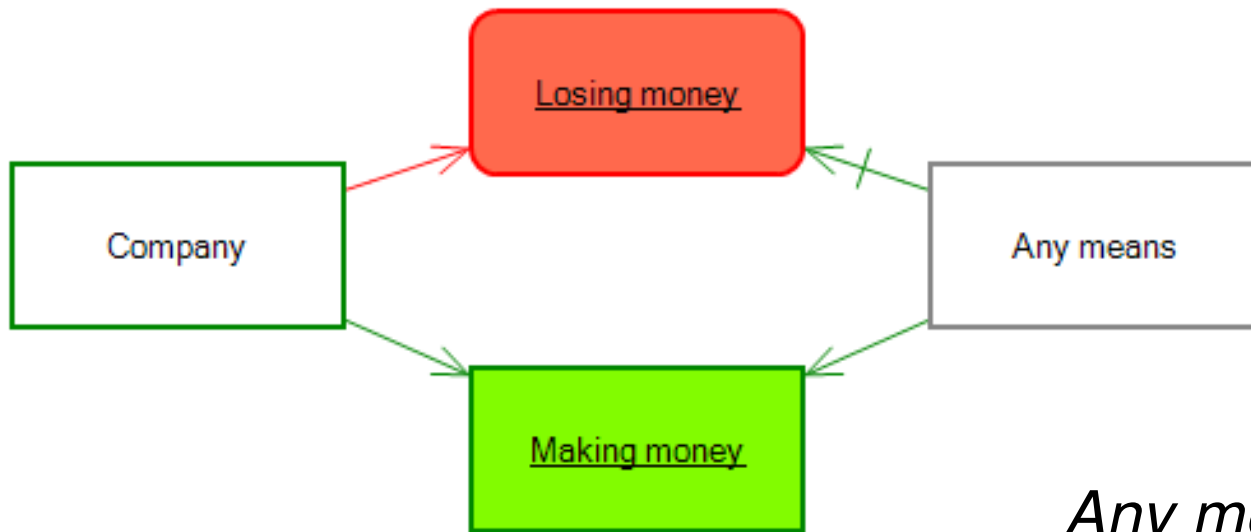

*Any means to an end*

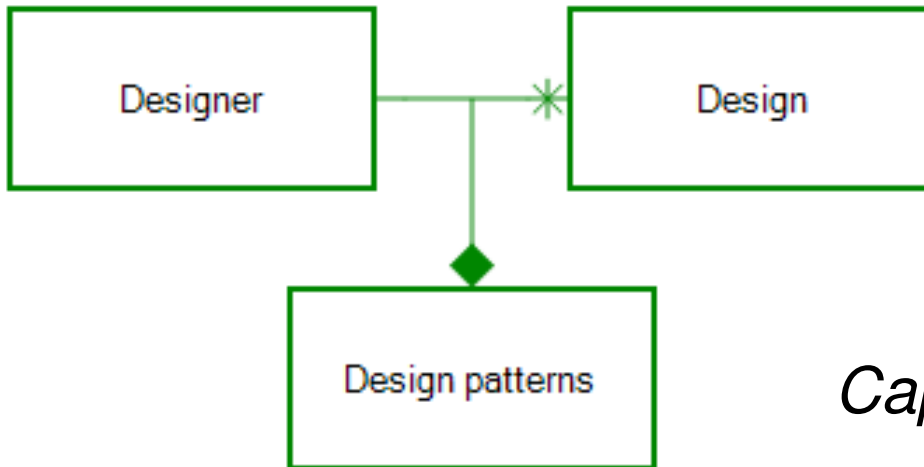

*Capturing design patterns*



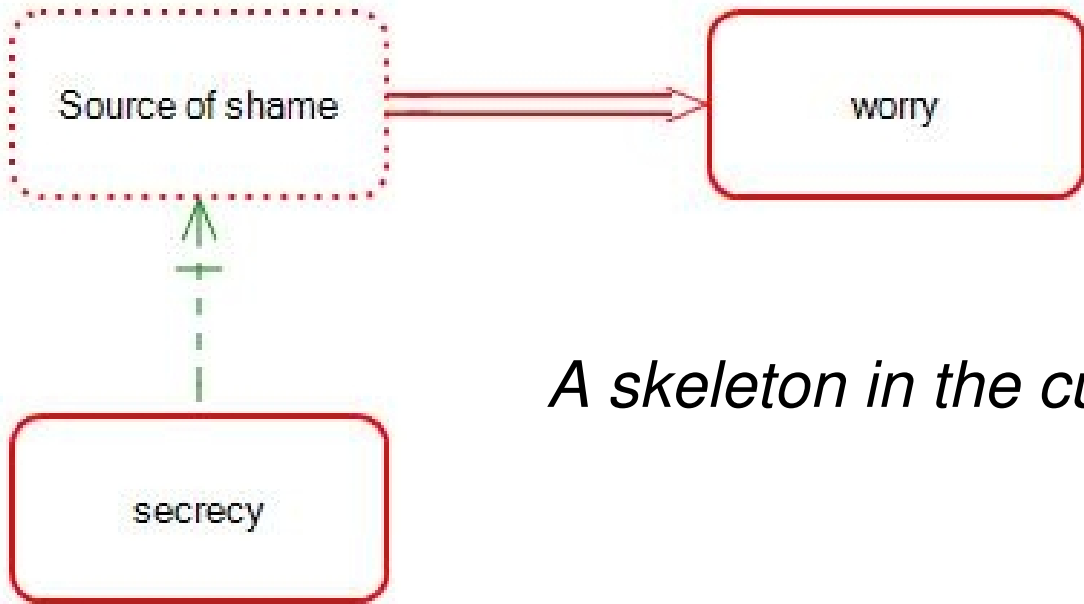

*A skeleton in the cupboard*

*SWOT diagram*

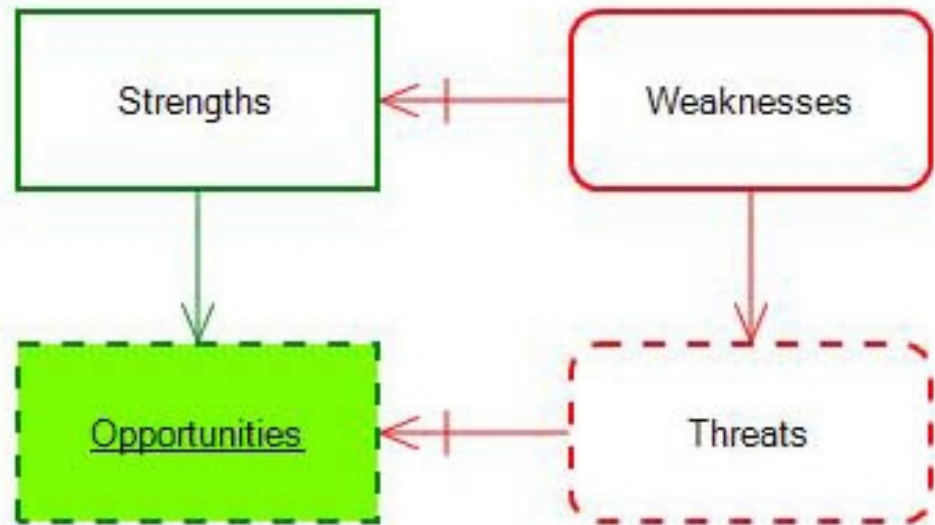

# Not system dynamics, but bridging towards system dynamics



*War on talent*

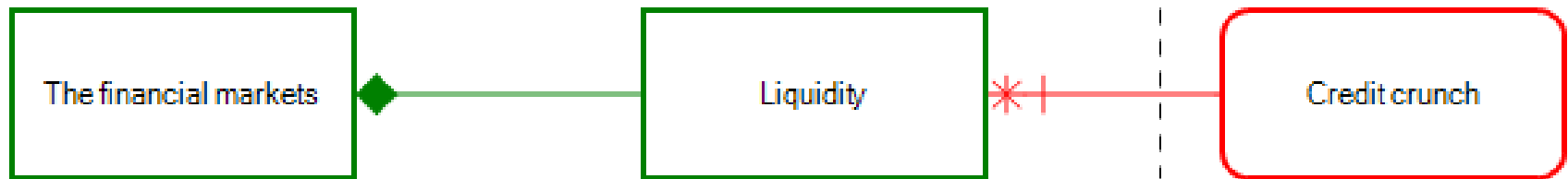

*Credit crunch*

# Europe fuel protests

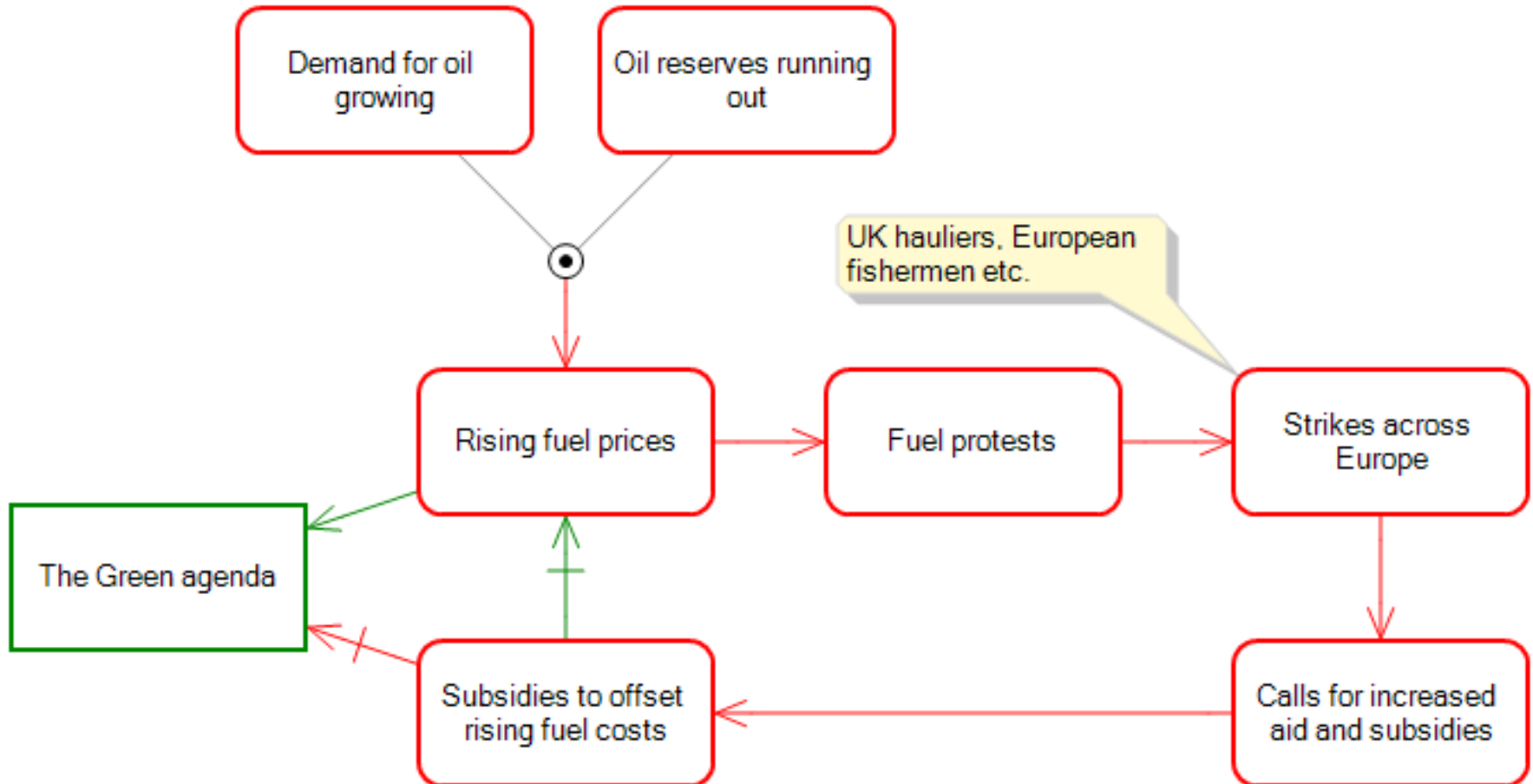

# Boys with knives – a model with two perspectives

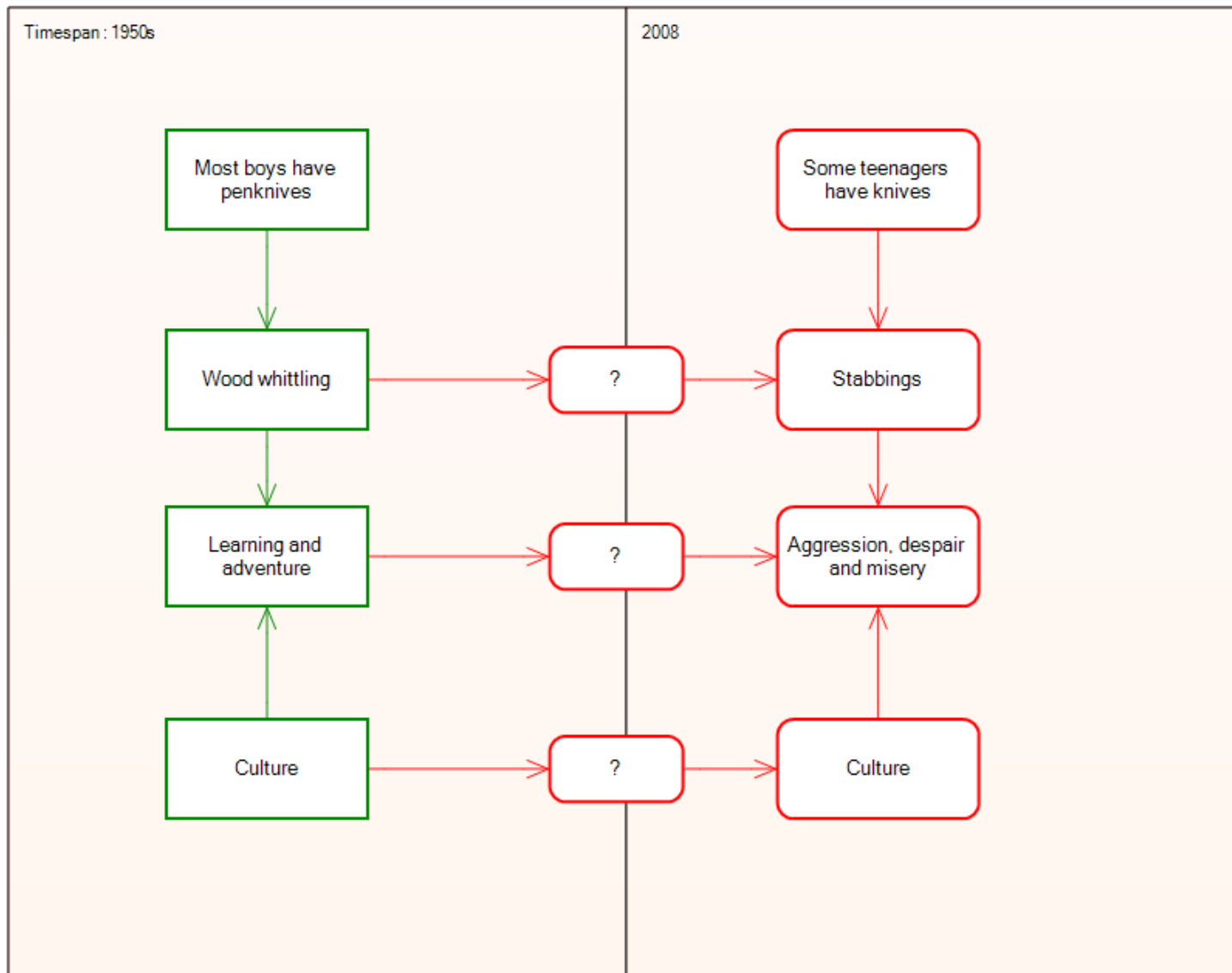

# Do you know about plantstones?

New Scientist 5th Jan 2008  
While Others Lock Carbon Away for Years

This is a solution

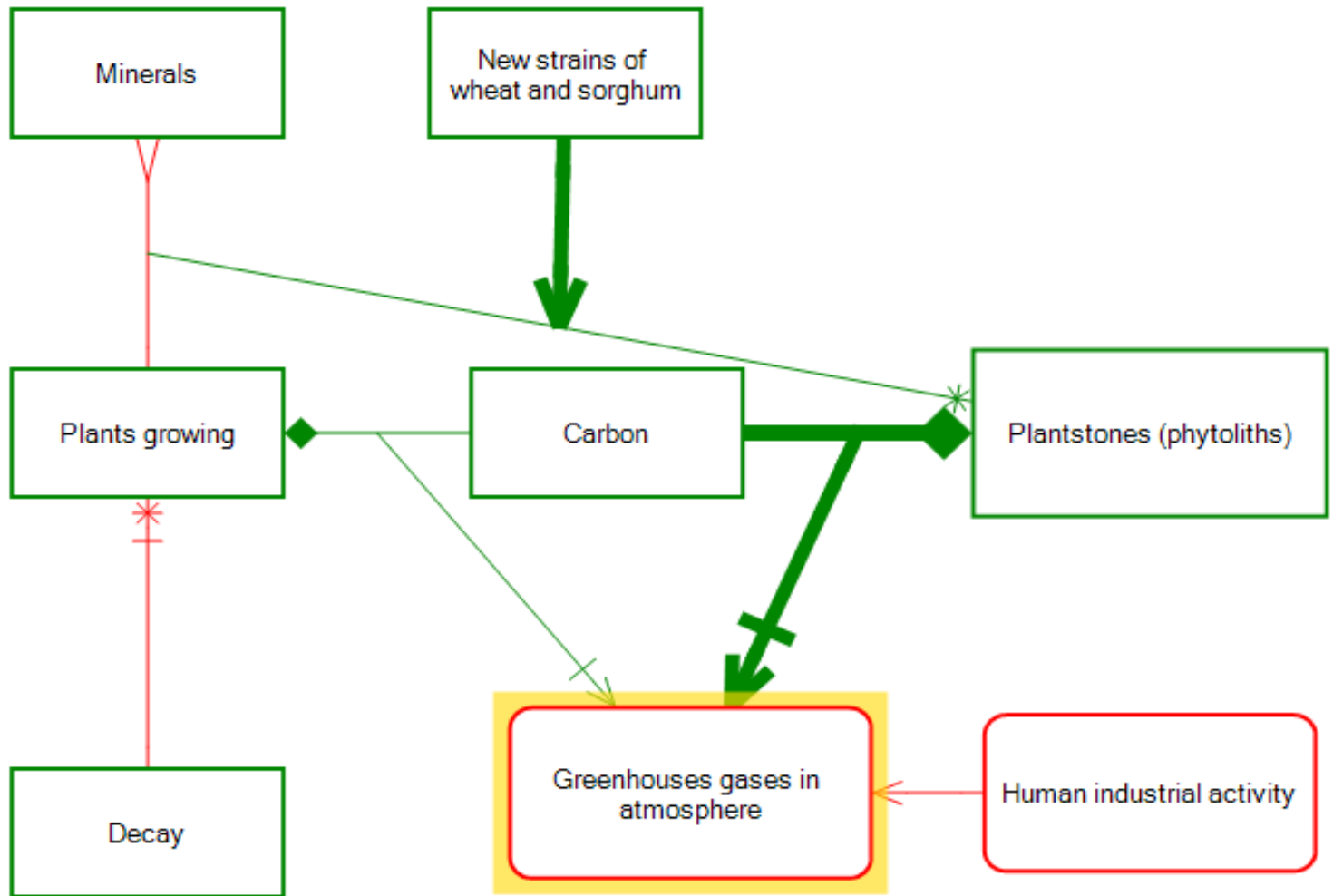

# Southbeach effect classes

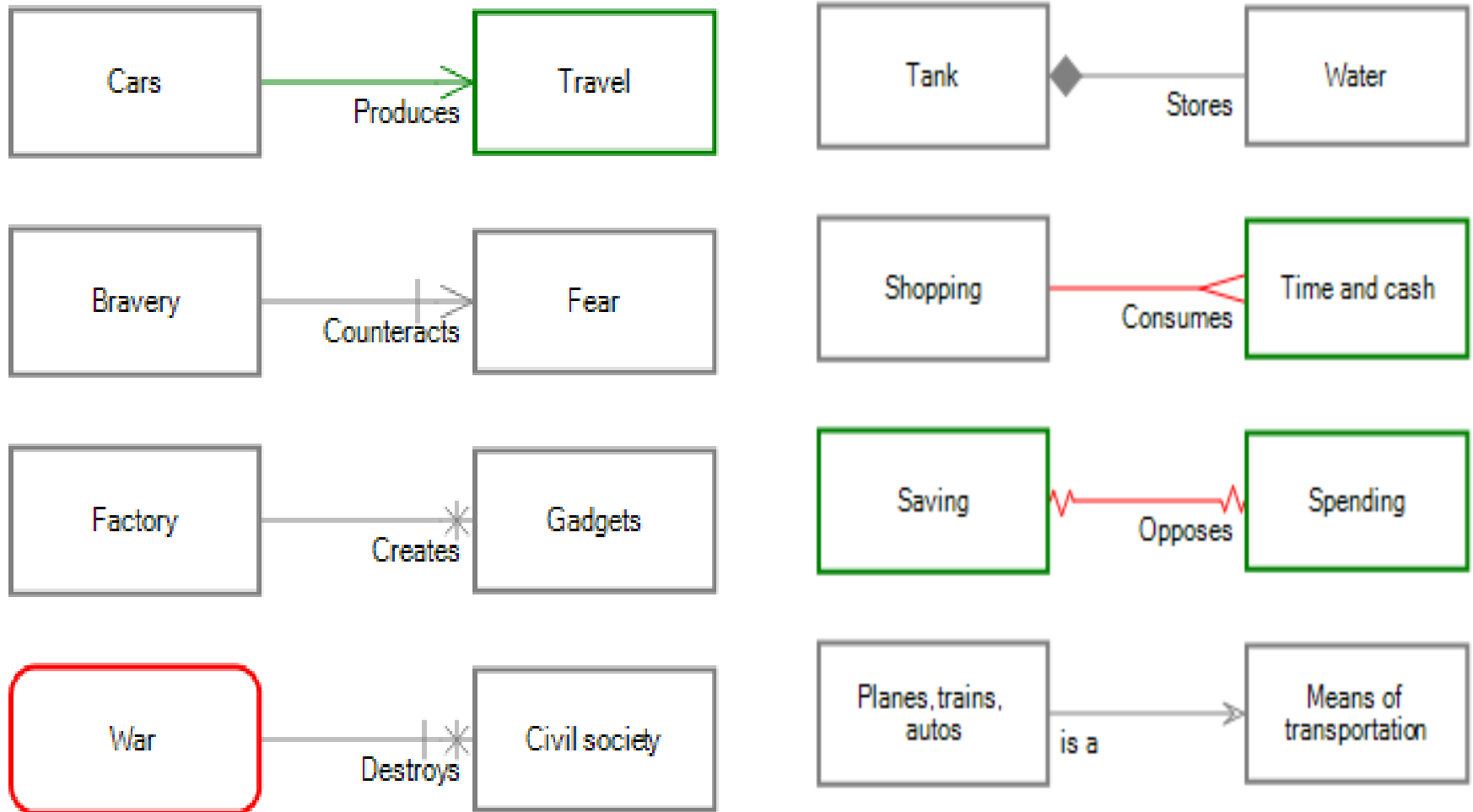

# Effect modifiers

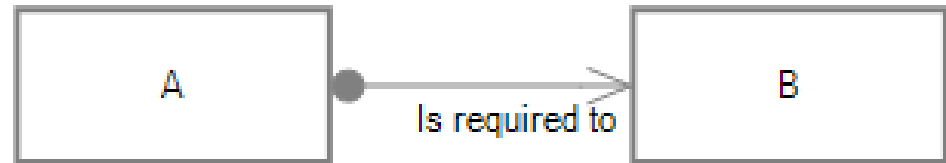
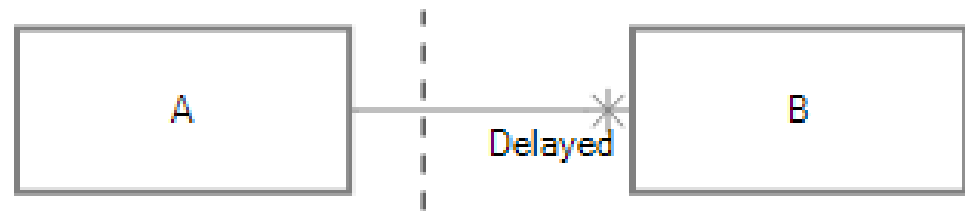
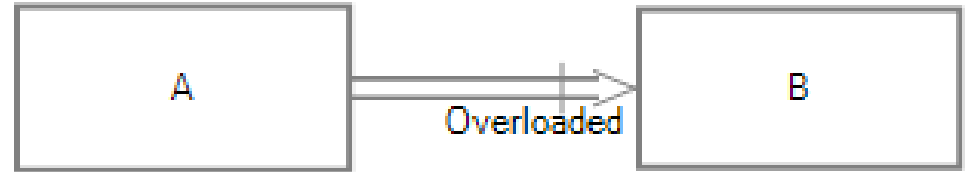
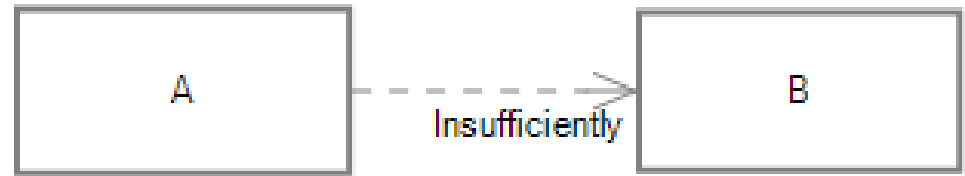

# Agent types

Useful

Harmful

Neutral (undecided or  
noviewpoint)

Goal

Potential - Useful if it  
existed

Focus - highlight

Risk

Potential - Harmful if it  
existed

Focus - highlight

## Agent types

Processes

Functions

Resources

Qualities

Events

Ideas

Things

Trends

## Separations

In Space

In Time

By Structure

By Perspective

By Aspect

By Role

By Probability

On Condition



# Combining attributes creates new meaning

Focus on this goal

Focus on this potential

Focus on this risk

A potential risk

Focus on a potential goal

Is the goal useful or harmful?

# Effects on effects, by effects, in the presence of

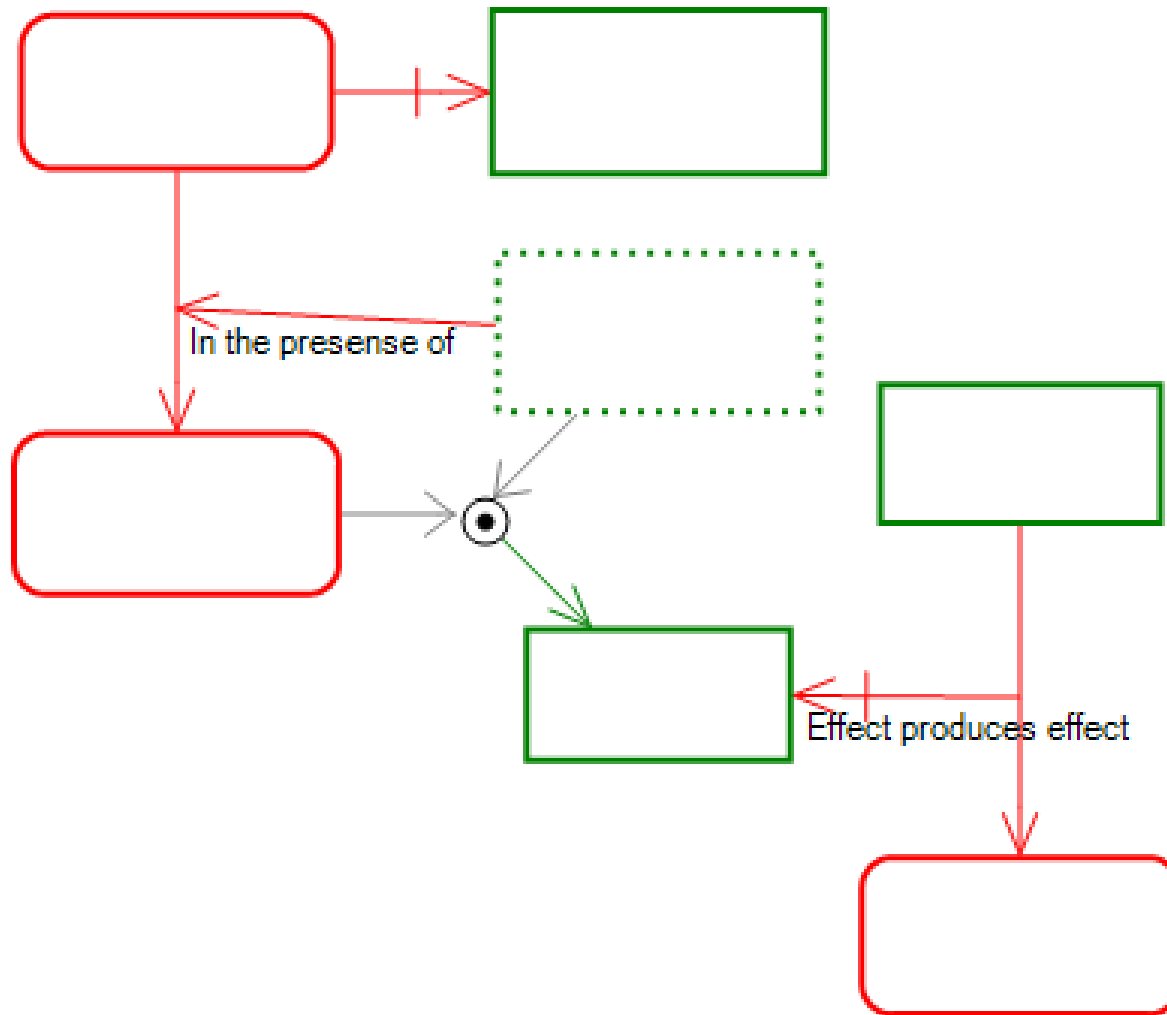

# Effect of poor service on brand

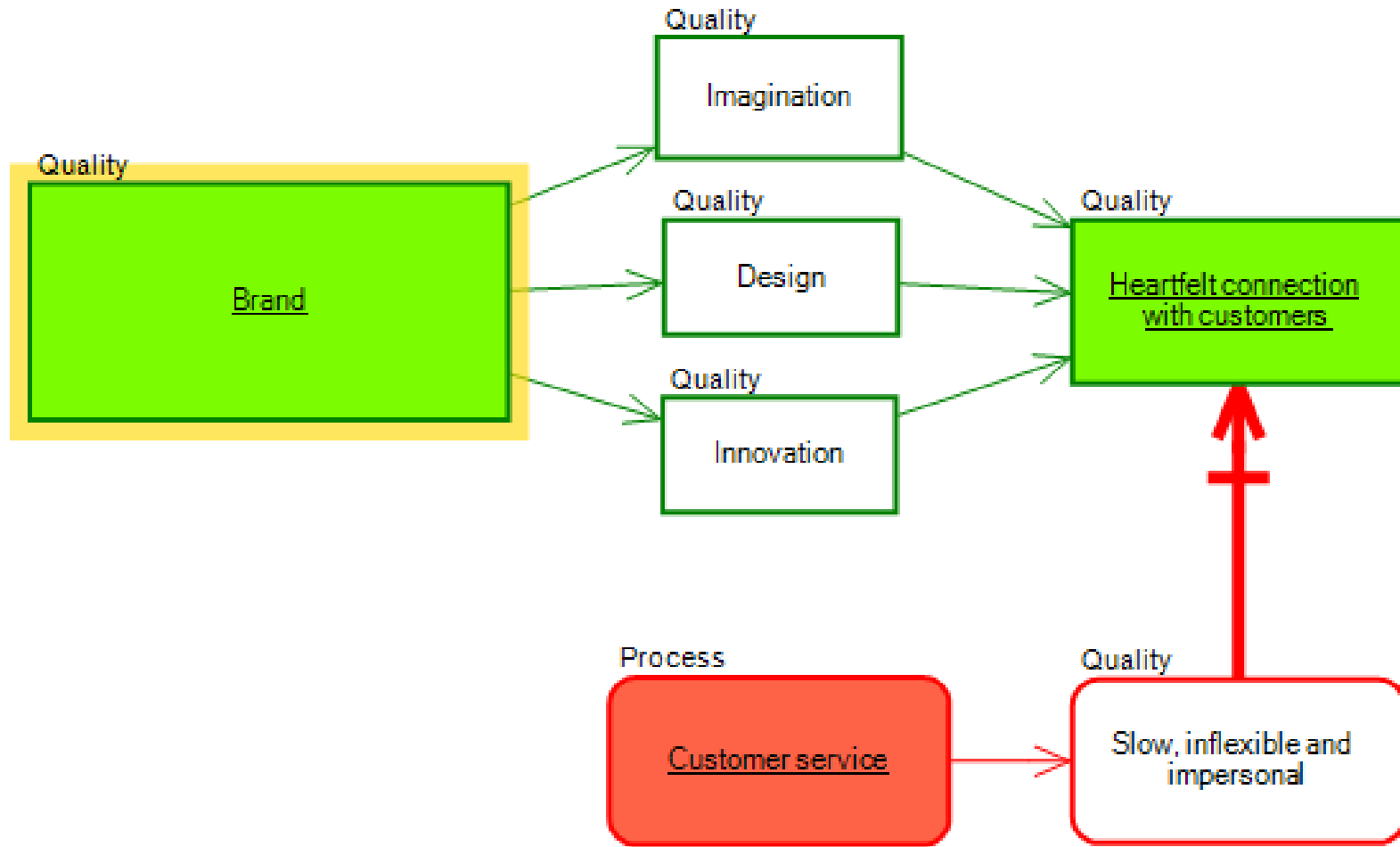

**Southbeach idioms have been chosen carefully**

**Southbeach idioms are semantic roots**

**Synonyms provide for rich expression**

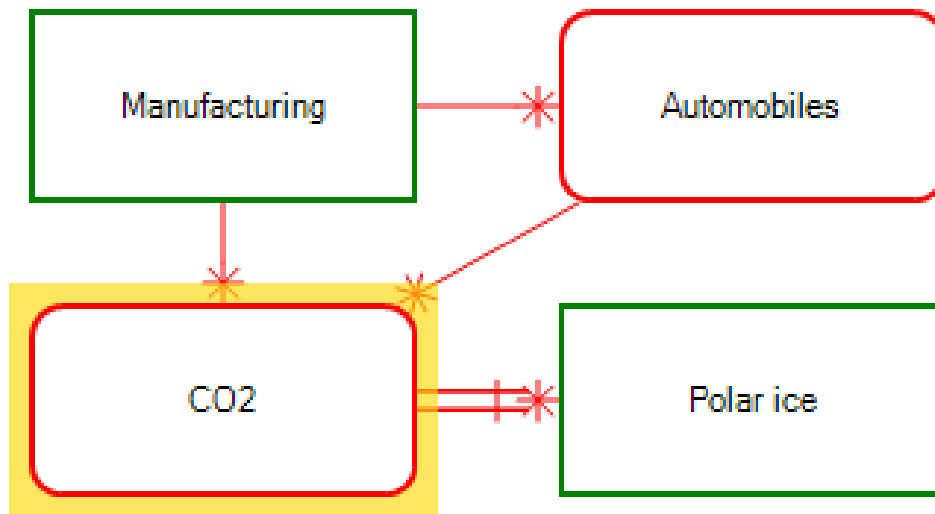

Creates =  
**Manufactures**

Creates =  
**Emits**

Destroys =  
**Melts**

# What came before

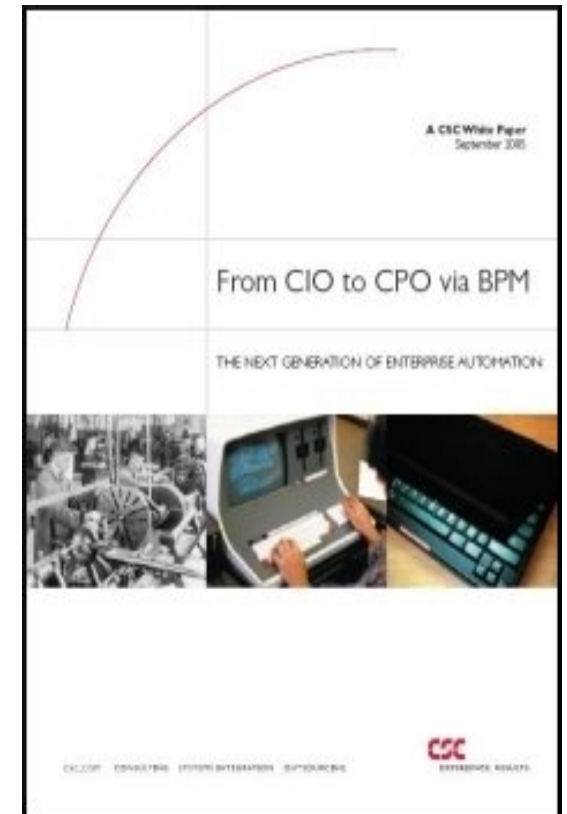
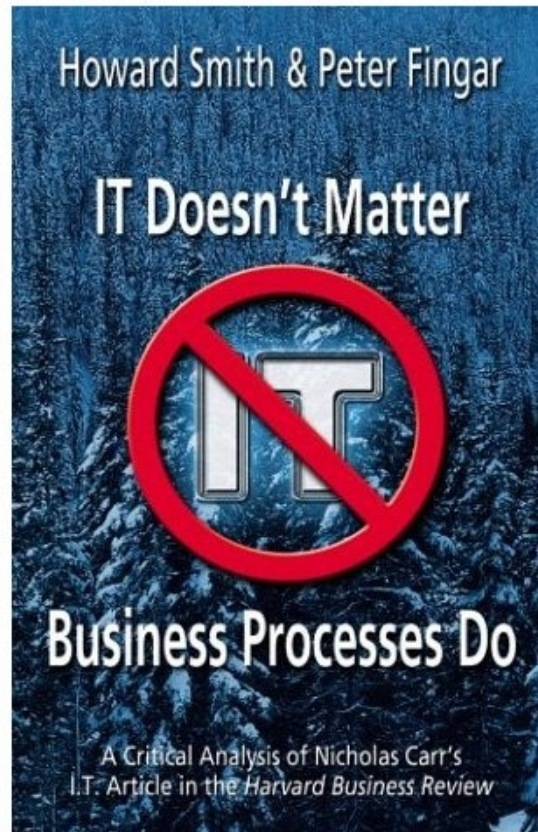
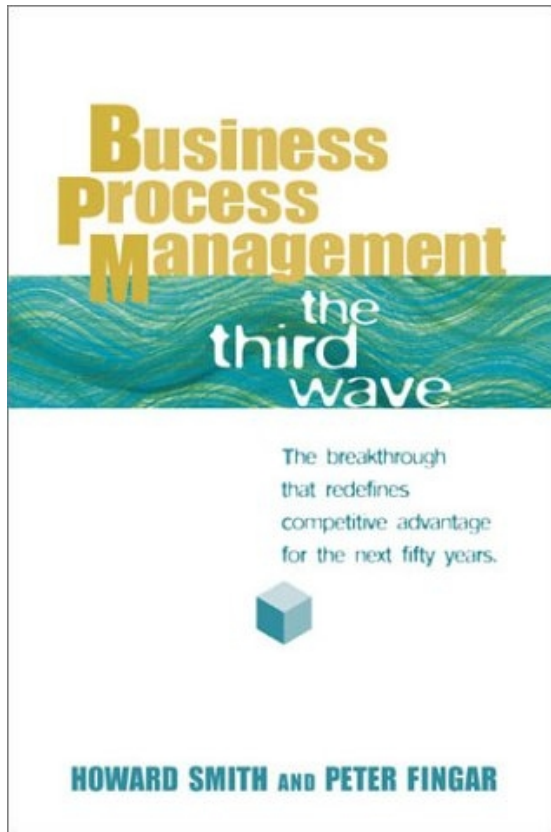

<http://howardsmith.editme.com>



## Process work is pervasive – methodologies were diverse (Still are?)

- G2000 organizations are almost universally embarking on multiple process improvement exercises to increase organizational efficiency or effectiveness
- These efforts go by many names, including industrial engineering, ISO certification, Six Sigma, Sarbanes Oxley, enterprise business architecture (EBA), business process improvement (BPI), business process re-engineering (BPR), Audit and Compliance, Rummler-Brache, Integrated Definition Function Modeling (IDFM) and Lean Thinking, to name a few

## As a result: diagrams and semantics are diverse

- Entity relationship diagrams
- ANSI standard flowcharts
- Process models, various
- Data flow diagrams
- Unified Modeling Language (UML/MDA) diagrams (activity, class, etc.)
- Catalyst, LOVEM
- Network diagrams
- CRUD (create, read, update, and delete) matrices
- IDEF charts (0 through 9)
- EPCs (event chains)

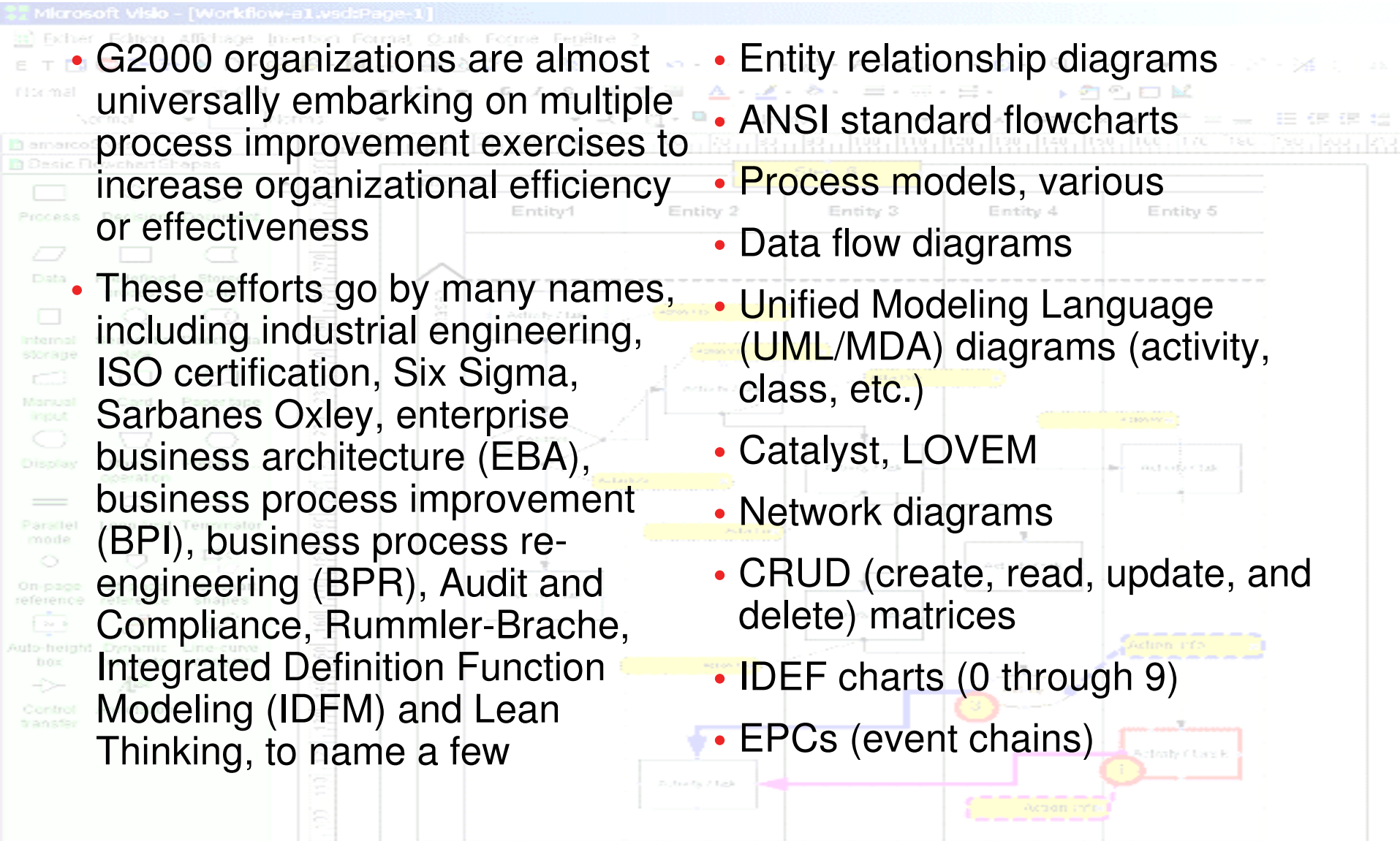



# BPMI.org 2002 ..... BPML, BPMN, BPQL, BPMS, BPEL





BPMN Information Home - Windows Internet Explorer

http://www.bpmn.org/

File Edit View Favorites Tools Help

BPMN Information Home



Object Management Group/  
Business Process Management Initiative

BPMN

## Business Process Modeling Notation (BPMN) Information

BPMN Specification Releases: [Frequently Asked Questions:](#)

[BPMN 2.0 RFP](#): Request for Proposals for version 2.0 of BPMN. See [FAQ](#).

[BPMN 1.1](#): OMG Specification, February, 2008 (PDF 3,372K). [Wikipedia Entry](#)

# BPMN

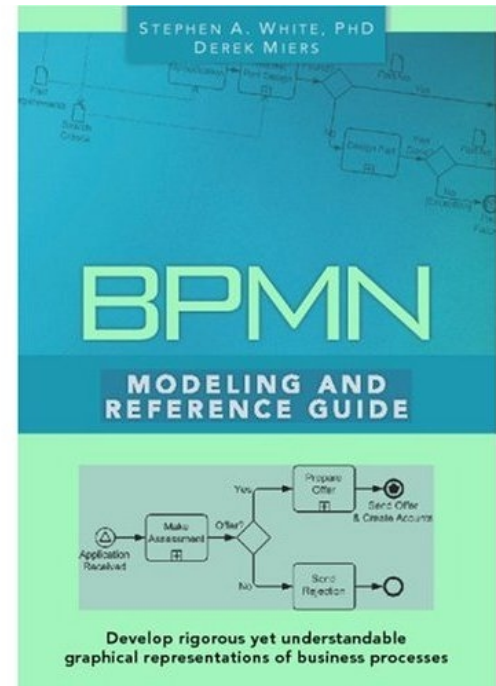
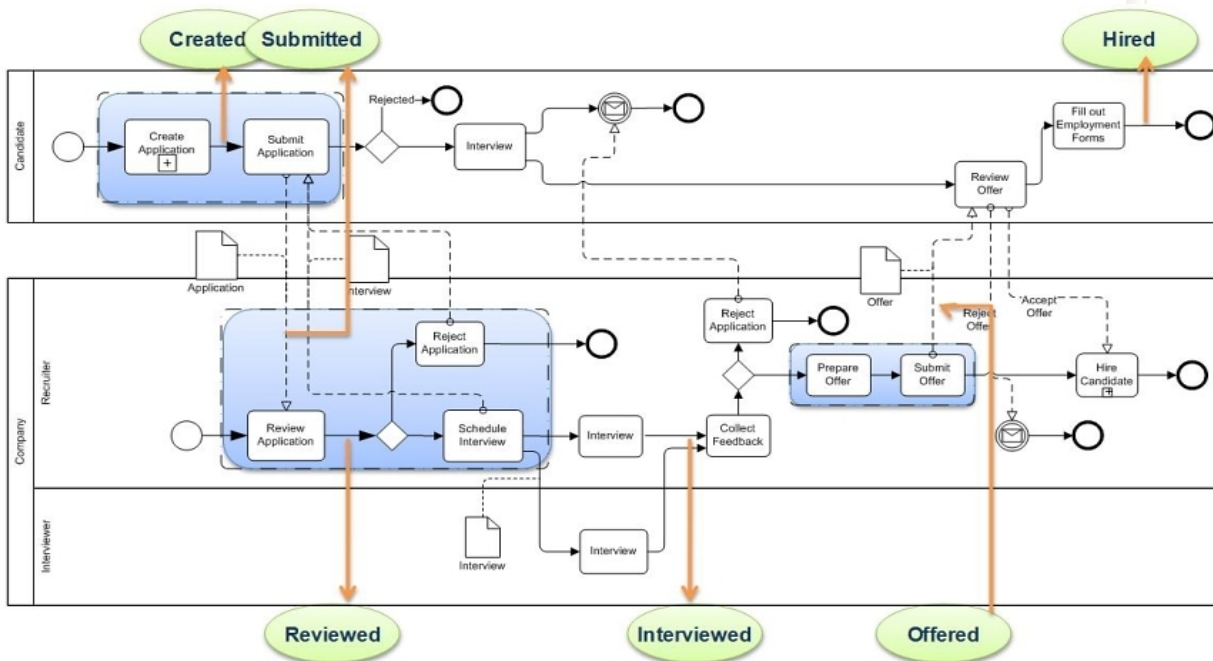



- COMPANY
- CUSTOMERS
- PARTNERS
- PRODUCTS
- SERVICES

- DISCOVER
- DOWNLOAD
- CONTACT US

## BPMN + BPEL + Open Source = SOA ROI

Intalio | BPMS is the only BPMS to natively support the BPMN and BPEL industry standards. An d best of all, it's 100% free. [Get it today!](#)

### BPM 2.0 AS EASY AS 1-2-3



1. Get a Free BPMS



2. Schedule Training



3. Get More Help

### INTALIO PRESS RELEASES

- 08/06/2008: Intalio | BPMS 5.2 Introduces Key Features for Enterprise Cust.
- 05/22/2008: Intalio User Conference June 17-18, San Francisco, CA
- 04/23/2008: Liferay Portal and Intalio Partner
- 04/08/2008: Intalio/NTT Data Intramart Automate Risk Management w/BPM
- 04/01/2008: Intalio | On Demand Launched, First Open Source BPM SaaS

### INTALIO IN THE NEWS

### REASONS TO TRY

- Open Source
- Eclipse Powered
- Native BPMN Designer
- Native BPEL Server
- Web 2.0 User Interface
- Zero Code
- One-Click Deploy

### SCHEDULED WEBINARS

- Sept 10, 2008 10 AM GMT+1
- Sept 19, 2008 10 AM PST
- Sept 29, 2008 1 PM EDT
- Oct 17, 2008 1 PM EDT
- Oct 29, 2008 1 PM EDT

# BPM



- “The future has arrived!”
- “I cannot believe it! I modeled and deployed my first process in a record time. I think you have a very nice tool. Congratulations!”

- “A game-changer in the industry”
- “A very powerful BPM tool for business analysts. It bridges the gap between Business and IT in an elegant, easy to use manner.”
- “Graphical process design tool, web-based workflow user interface, automatic generation of forms, and enterprise-class open-source architecture. It has everything our customers have been asking for.”
- “There is more to the tool than meets the eye. Its capabilities will surprise you.”
- “Using Intalio BPMS, we experienced massive acceleration in deploying portal-based business processes”

# Management gurus get attention

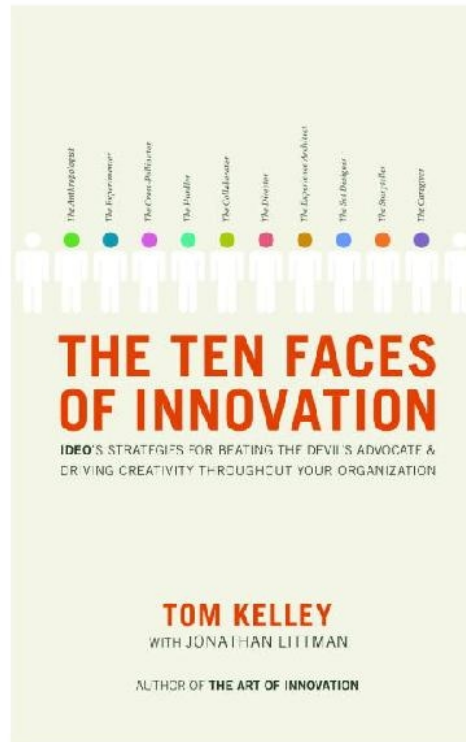
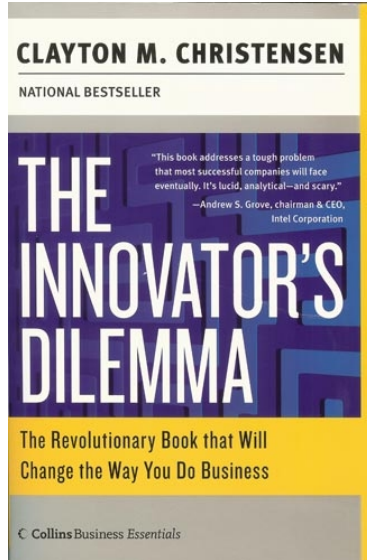

# The alternative history of innovation - TRIZ

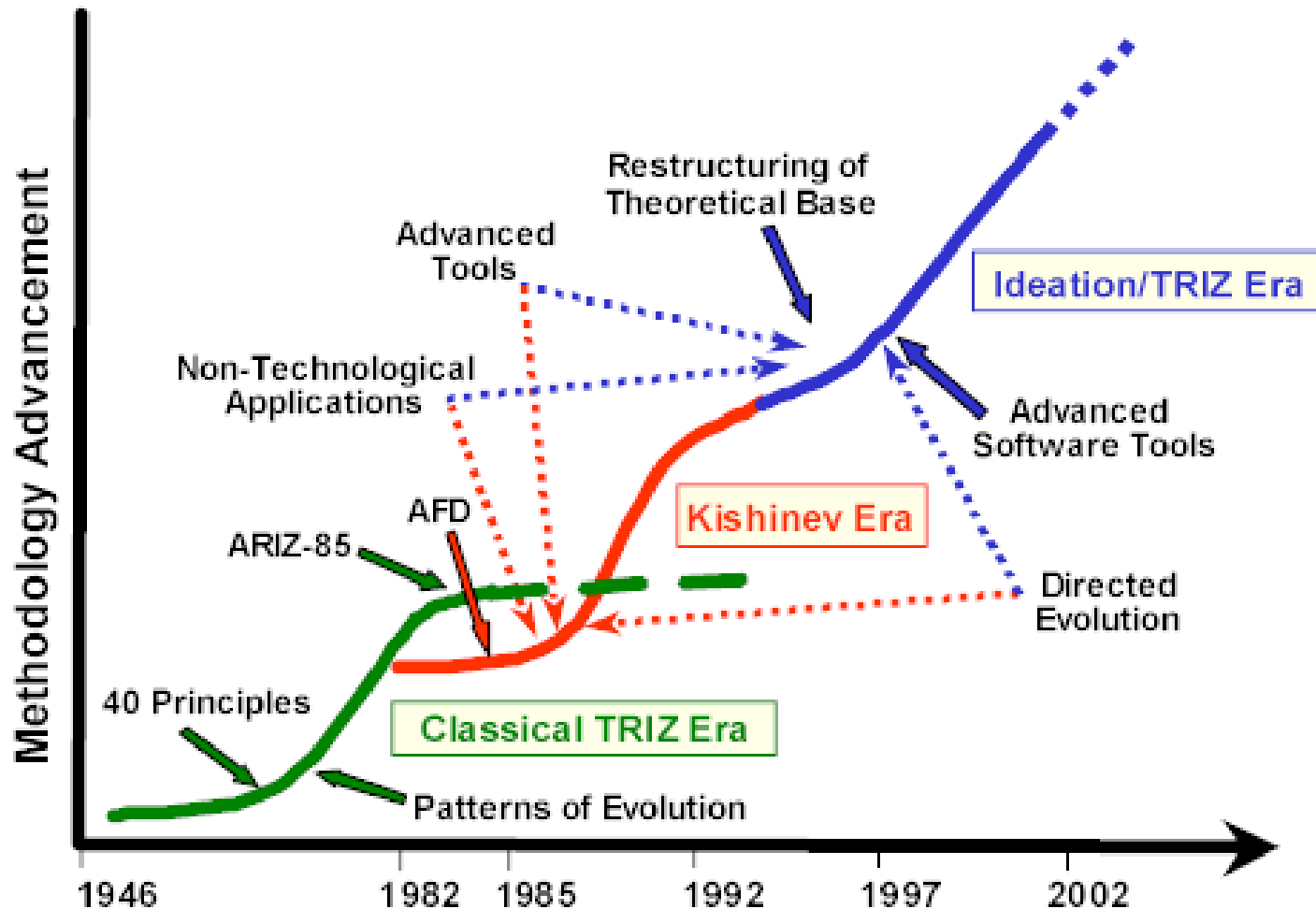

Source: Ideation International

# The roots of systematic innovation should be acknowledged

- Genrich Saulovich Altshuller
- Father of TRIZ
- A process for creativity?
- 15 October 1926 – 24 September 1998

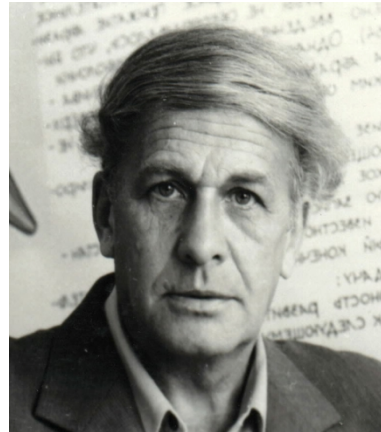

- Boris Zlotin and Alla Zusman
- TRIZ masters and methodologists
- Pioneering the foundations for the development of a modern TRIZ methodology
- Ideation International
- [www.ideationtriz.com](http://www.ideationtriz.com)

# Asking questions drives innovation

Does A really produce B directly?

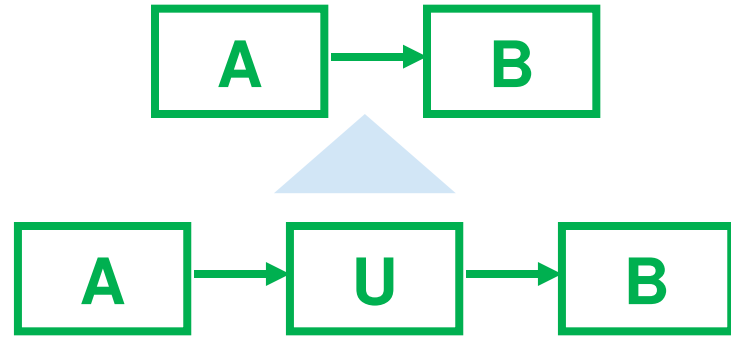

What is harmful about A?

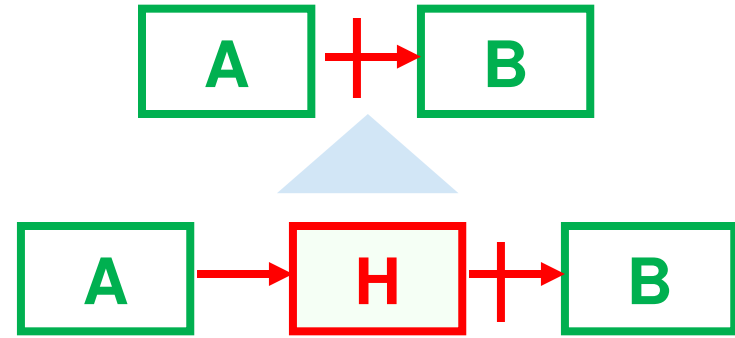

What direct consequence of A yields H?

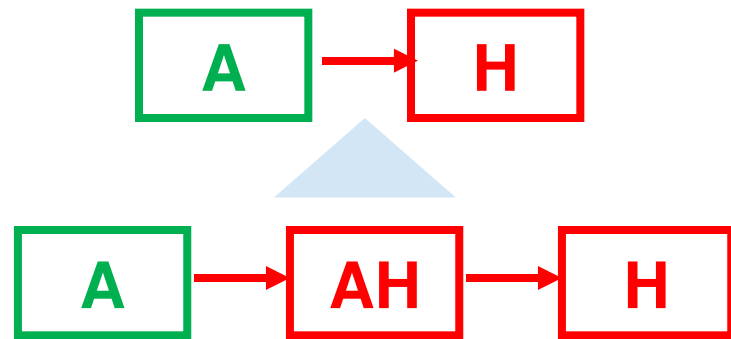

What specifically about A counteracts H?

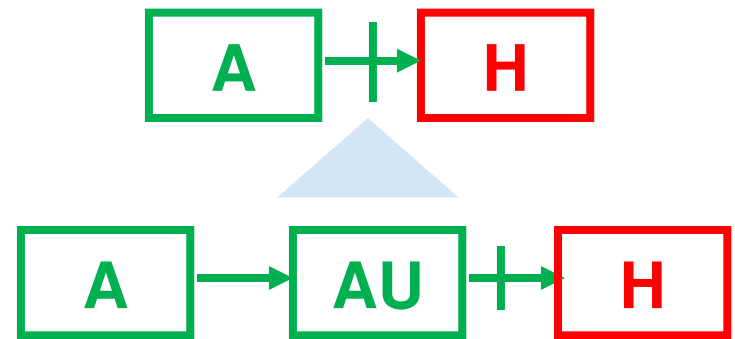



# Models can suggest improvements

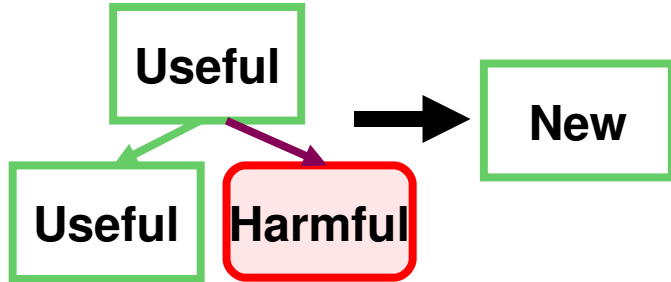

## *Example 1*

Replace the system with a new system that does not exhibit the harmful function

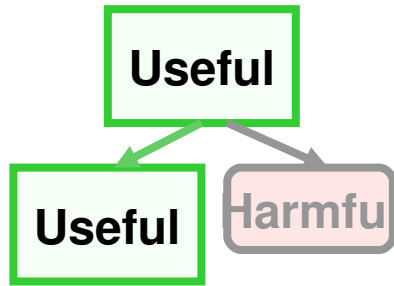

## *Example 2*

Find a way to eliminate or reduce the harmful function

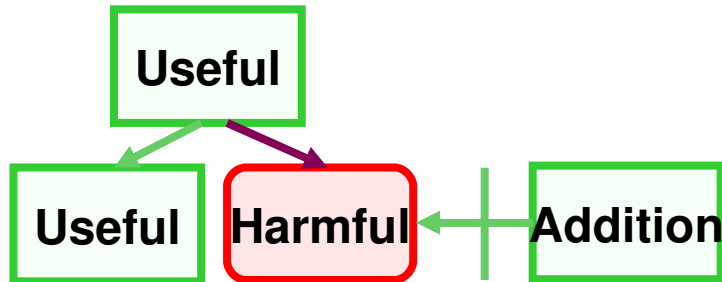

## *Example 3*

Add a compensating function to limit the impact of the harmful function



## More examples of innovation

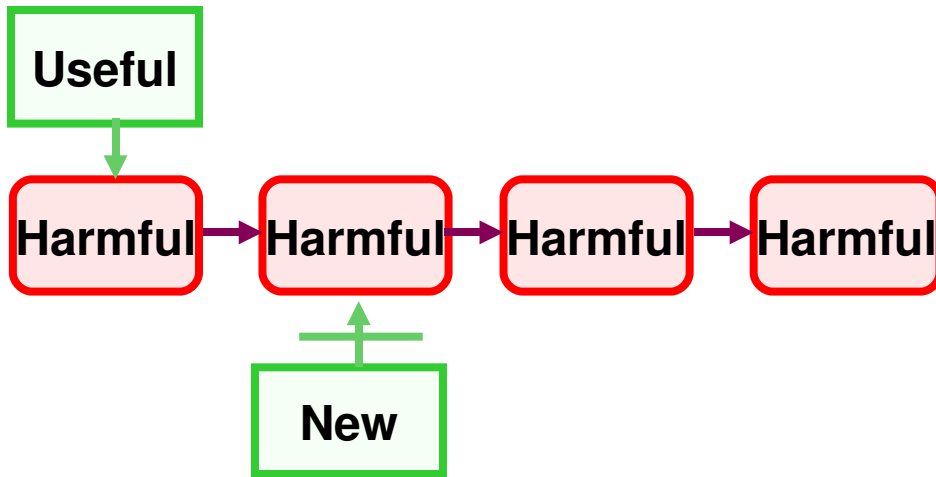

### *Example 4*

Compensate a harmful side effect to break a chain of harmful knock on effects

### *Example 5*

Amplify the useful output, to the extent that the harmful function becomes insignificant

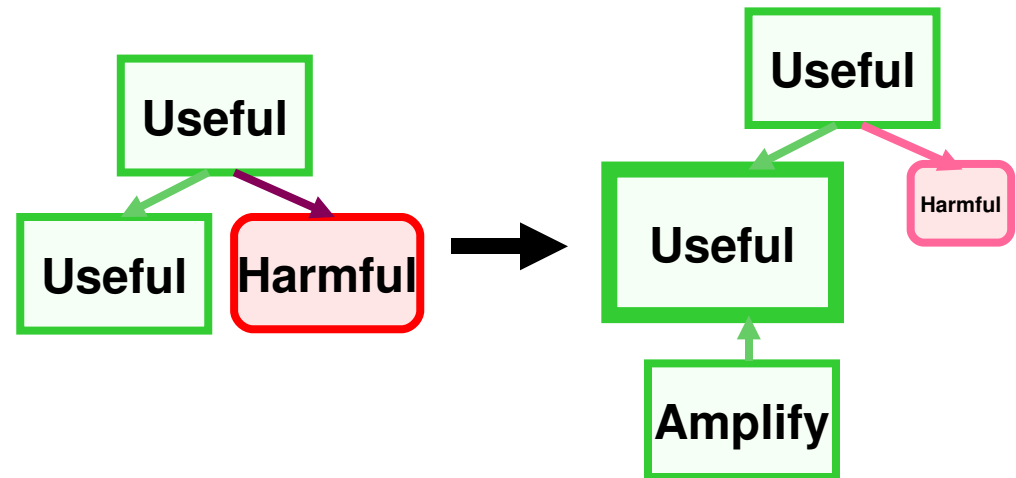

**Every thing that exists, or is yet to exist, is attended by an inseparable companion ...**



# The innovation shadow-self

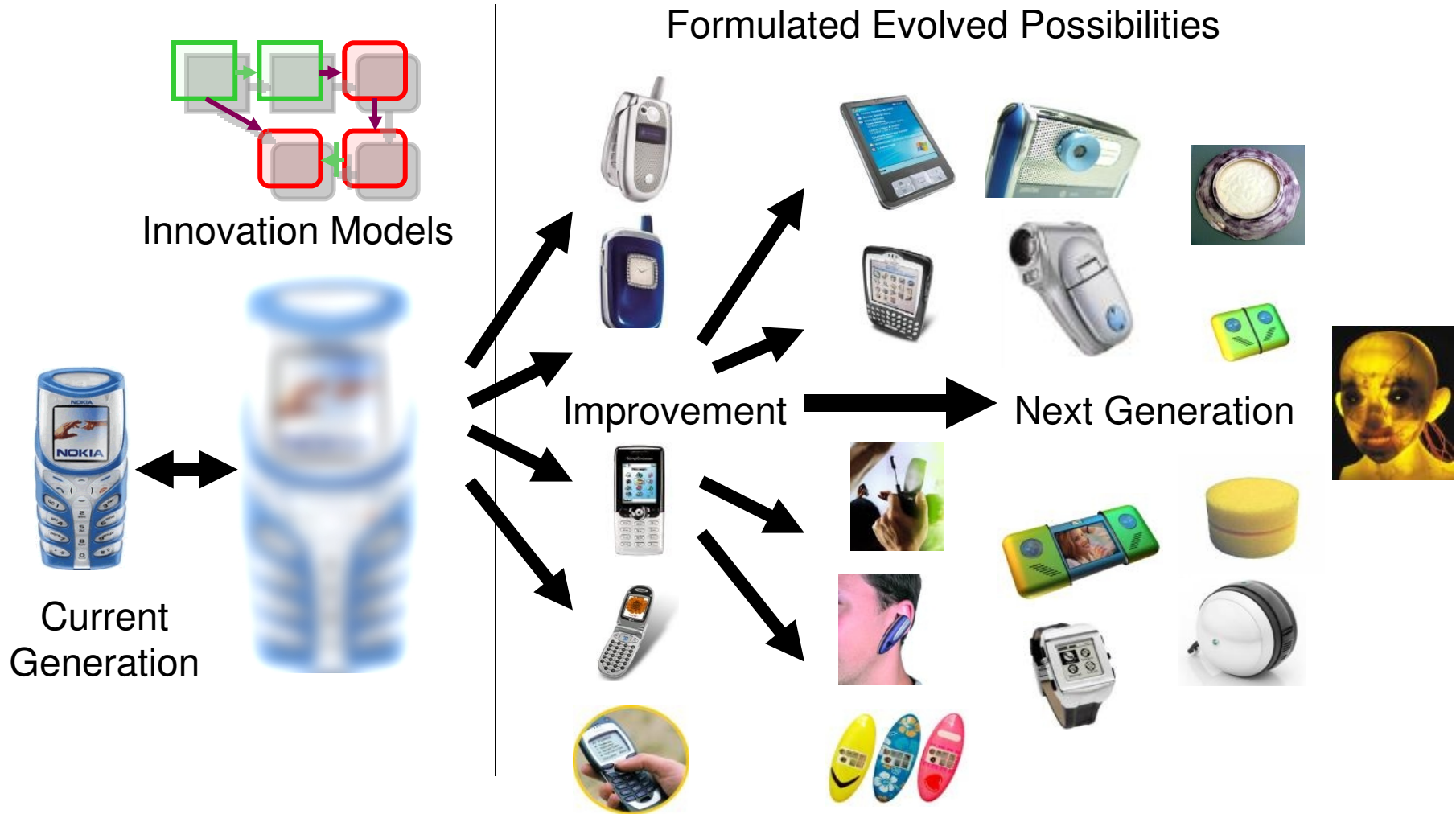



# Any existing intellectual property can be open to innovation

Schematic, diagram, document, process, etc.

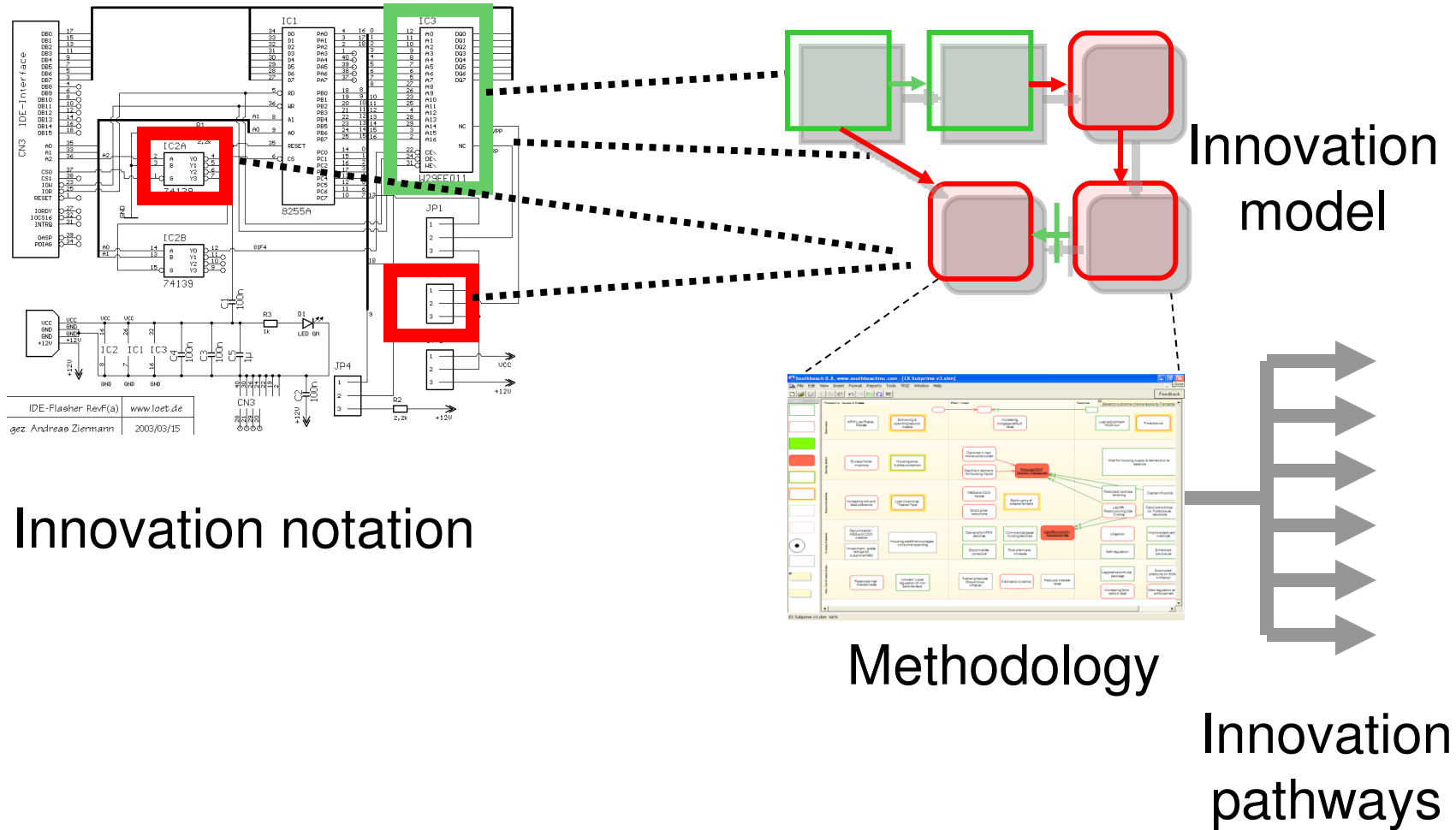

**TRIZ uses a simple notation which many like ...**

**but is it too simple?**

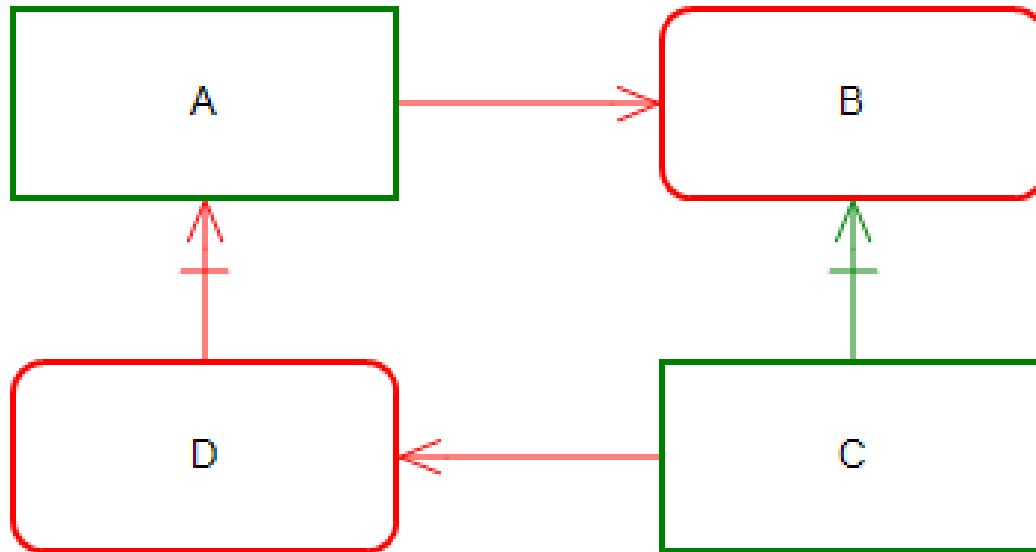

Useful

Harmful

Produces

Counteracts

# Southbeach notation ... more expressive yet still simple

Agent attributes - perspective

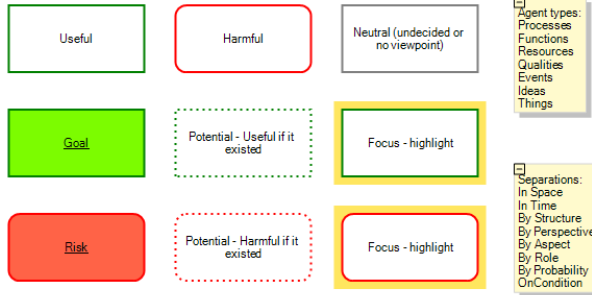

Attributes can be combined, e.g.

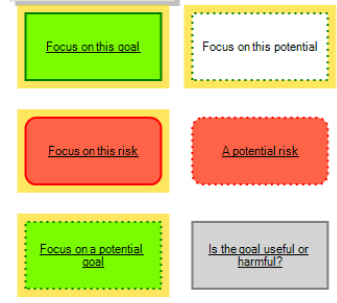

Effects between agents and effects

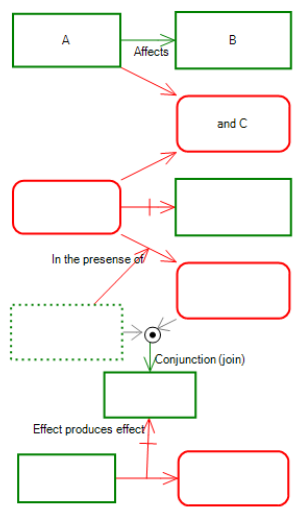

Types of effects (influences, relationships)

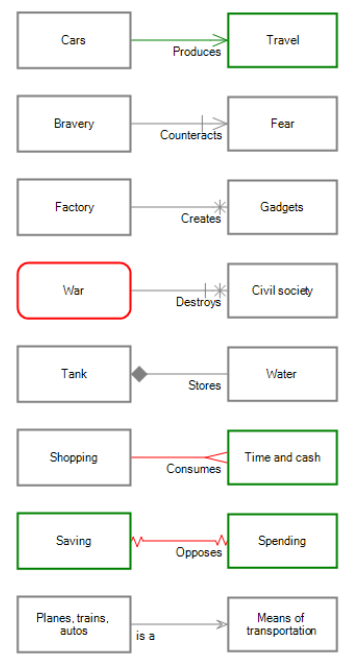

Variations of effects

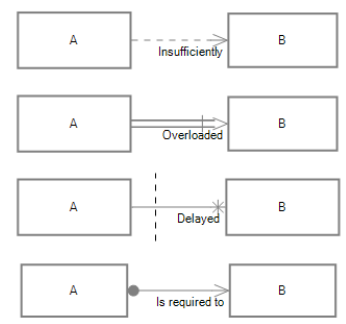

Relative strength of agents and effects



Line types for all effects and variations

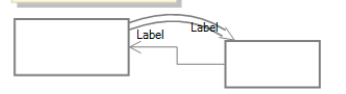

Annotations - labels

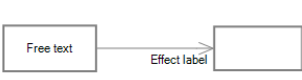

- New visual diagramming and modeling style
- Extends TRIZ notation
- Fosters integrative thinking
- Model from multiple perspectives
- Resolve contradictions
- Suggest ways forward
- Applications in business, design, engineering, change management, process work
- Appeals to management consultants and architects

# Does not replace any other notation

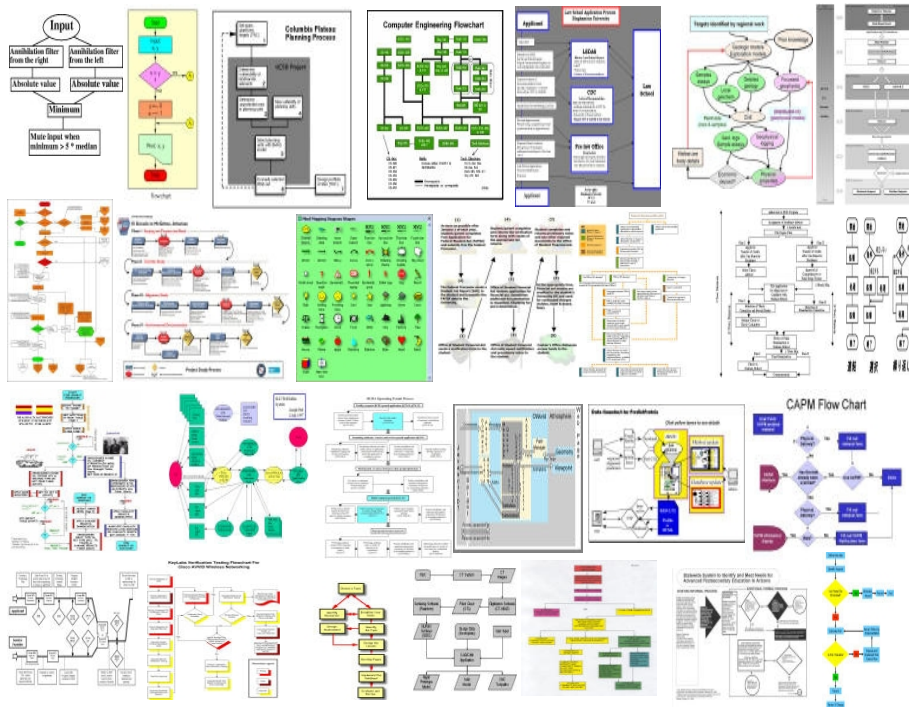

- Complements all other notations
- Draws from previous notations
- Can be used to mark up other notations
- Stands in its own right as a useful new notation
- Formal semantics, but will be used flexibly
- Modeling of perspectives



Toolbox

- [Green box]
- [Red box]
- [Green box]
- [Red box]
- [Yellow box]
- [Orange box]
- [Dashed box]
- [Dashed box]
- [Dashed box]
- [Circle with dot]
- [White box]
- [Yellow box]
- [Yellow box]

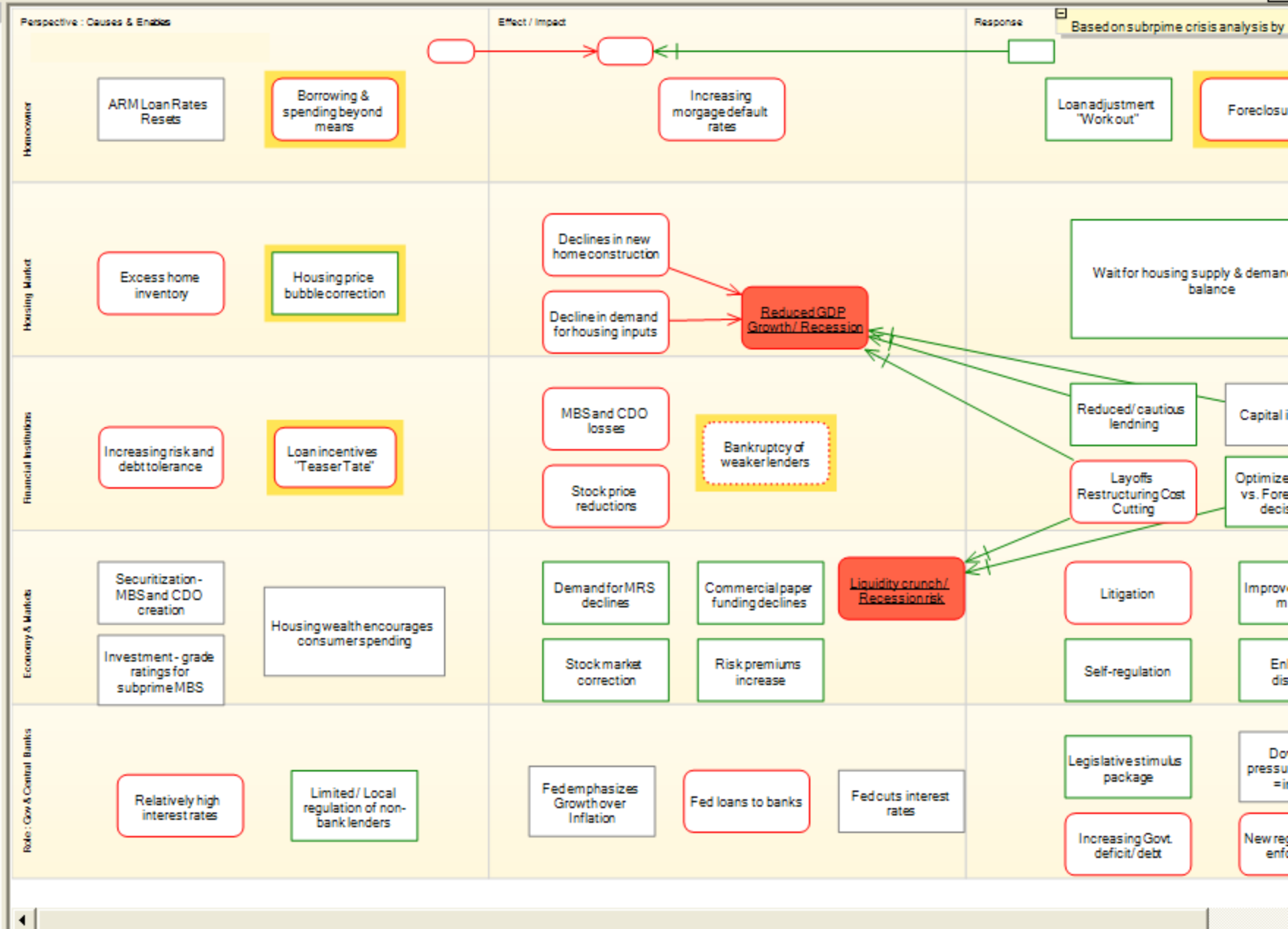



# Executable models?

## Run the process - tasks

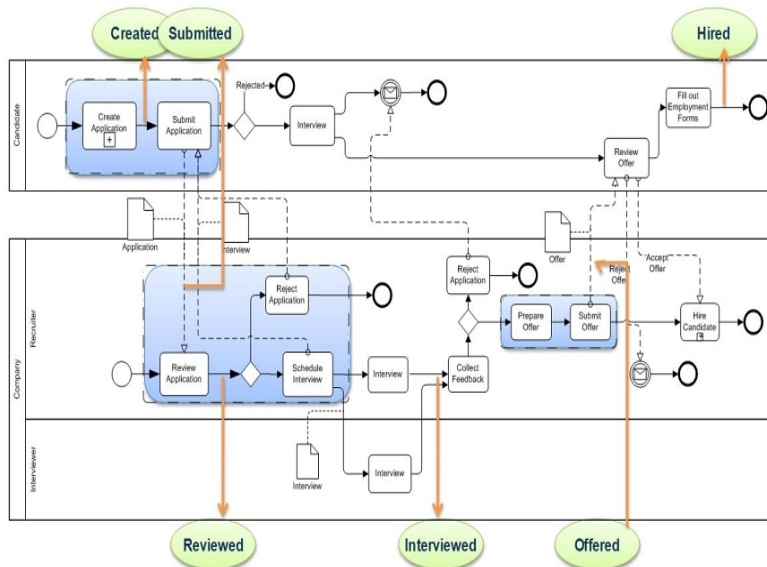

## BPMN/BPMS

## Improve the process - suggestions

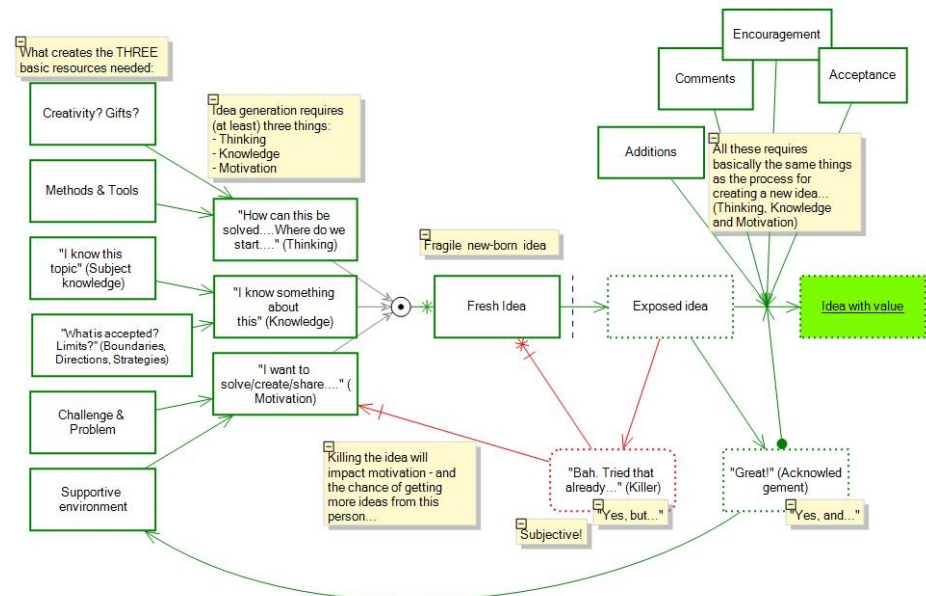

## Southbeach

Model courtesy of Anders Jangbrand, CSC

http://howardsmith.editme.com

http://www.southbeachinc.com



## The Innovator Is A Problem Solver



### Do you have problems?

An obscure methodology originating in Russia in the 1940s, which has mainly been applied in engineering, is nevertheless being used today by CSC's solution architects working on their customers' most complex problems. It's called TRIZ. This article explains how TRIZ works and why we think it will become an important tool for the CIO and across the IT organization.

The IT portfolio brings a problem portfolio that may at times you delighted the business. Was it the result of systematic engineering unexpectedly solving a key problem that was hindering progress? The problems you inherited from your predecessor are the solutions they created to counteract older problems buried deep in the history of your organization. How will you avoid leaving a similar legacy to your successor? If you must now cut further costs at the same time develop valuable new business processes, there is a methodology associated with the existing legacy must be resolved. Can you

**Howard Smith and Mark Burnett**

Howard Smith, a research associate of the Leading Edge Forum, is CTO for CSC European Group and a leader of CSC's global BPM and enterprise architecture centre of excellence. An early advocate of process technology and a cofounder of BPM.org, Howard is a regular columnist at BPM Trends and author of two books about IT and business processes.

hsmith23@csc.com

## Do You Have Problems? A TRIZ Overview



## What Innovation Is

White paper  
38 pages

P-TRIZ  
Series

A BPT COLUMN	P-TRIZ Formulation
<p><b>Process Innovation</b></p> <p>March 2006</p>  <p><b>Howard Smith</b> CTO CSC European Group Corporate Office of Innovation Computer Science Corp. hsmith23@csc.com</p>	<p>Last month we introduced readers to Process-TRIZ (P-TRIZ), a new method of use to anyone documenting, analyzing, or re-designing business processes. Developed by Mark Burnett and Howard Smith at Computer Sciences Corporation, P-TRIZ is a methodology for identifying process reengineering options and the associated solutions.</p> <p>While workflow, rules engines and BPM systems are proving effective at introducing new processes', the design of such processes has to be determined before they can be deployed – with or without new technology. That's where P-TRIZ can help. In this article, I show how a P-TRIZ model is used to generate an exhaustive list of re-design options. This first step in P-TRIZ is called <i>formulation</i>.</p> <p>In P-TRIZ, every process model (swimlane model, BPMN diagram etc.) can be accompanied by one or more corresponding <i>process innovation models</i>. Where the swimlane model describes how the process should execute, the process innovation model describes how the process can be <i>improved</i> or <i>re-invented</i>.</p> <p>Process innovation models are easy to read and are a great aid to communicating what is good and bad about any process. The notation requires only two types of boxes and two types of lines:</p> <div style="display: flex; align-items: center;"> <div style="border: 1px solid green; padding: 2px; margin-right: 5px;">Useful</div> <div style="margin-right: 5px;">A function considered useful in this context</div> </div> <div style="display: flex; align-items: center;"> <div style="border: 1px solid red; padding: 2px; margin-right: 5px;">Harmful</div> <div>A function considered harmful in this context</div> </div>

<http://www.bptrends.com>

<http://trizmethods.blogspot.com>

Search  
Southbeach  
TRIZ  
P-TRIZ

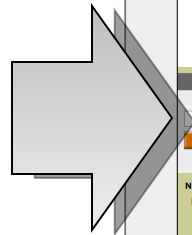

Many articles plus  
Southbeach Spec (70 pages with examples)



# Final thought

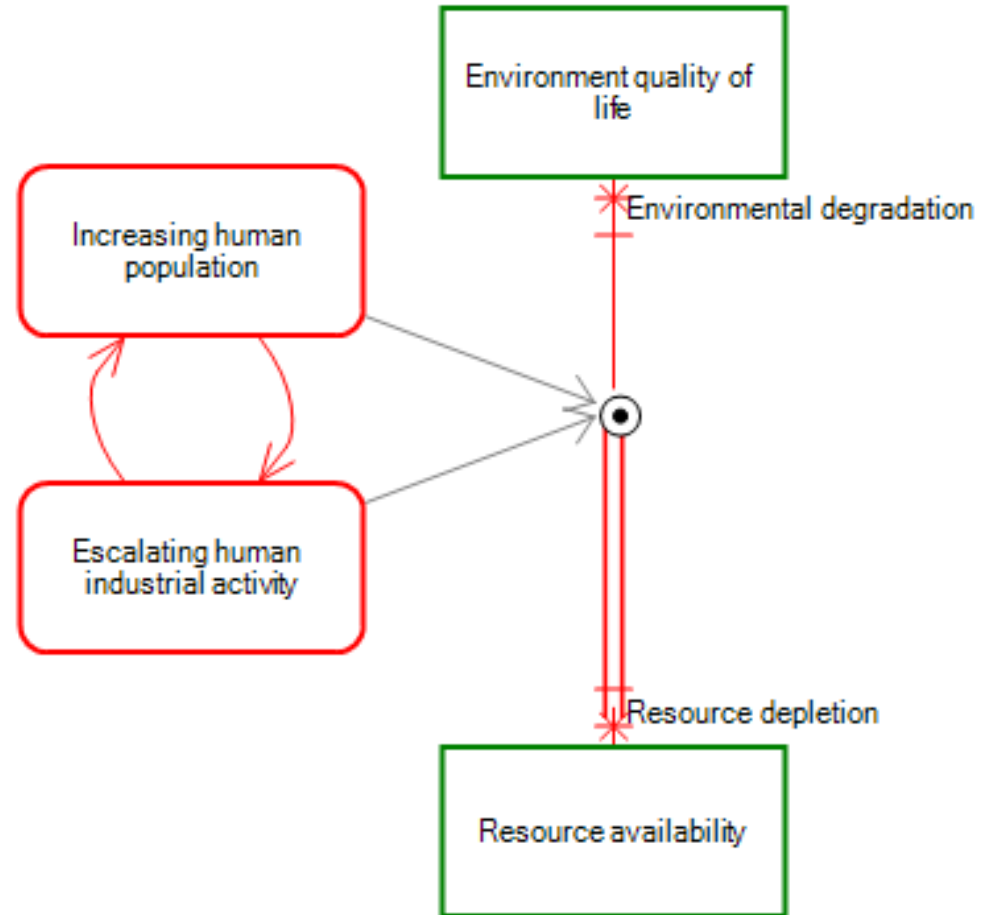

[hsmith23@csc.com](mailto:hsmith23@csc.com)

<http://howardsmith.editme.com>

<http://www.southbeachinc.com>

# PURPOSEFUL

We're guided by an industrious attitude and a determination to deliver on our commitments.

AT CSC, WE  
EXPECT OUR  
CLIENTS TO  
EXPECT  
MORE

CSC

# INGENIOUS

We thrive on exploring new ideas and create surprisingly inventive, far-reaching solutions that go beyond expectations.

# PASSIONATE

We are deeply committed to our clients, because we believe that collaboration yields inspiring solutions.